

# INSTRUCTIONS FOR VERTICAL, TWIN-PISTON, VALVE REPLACEMENT KIT

**NOTE:** These instructions are for the new style cylinder head shown in the illustration below.

## Replace the intake valves as follows:

1. Loosen and remove the exhaust tube from the head.
2. Loosen and remove all the head screws from the head (key numbers 1 - 3).
3. Gently pry the head (key number 6) from the pump cylinders. Remove the old gasket.
4. Assemble the new flapper valves by placing them in the cylinder head as shown below.

## Replace the exhaust valves as follows:

1. Loosen all the head screws (key numbers 1 - 3), remove the top plate screws (key numbers 1 & 2).
2. Gently remove the plate (key number 4). It is best to replace the O-ring (key number 5) when you re-assemble the top plate.
4. Replace the flapper valves and restrictors as shown below.

## Assemble the top plate and head to the pump as follows:

1. Place the O-ring in the groove surrounding the outlet valve chamber. Silicon grease may be used to hold the O-ring in the groove.
2. Position the cylinder head gasket onto the top of the cylinder along with the cylinder head. Be sure the two center holes in the cylinder, the gasket, and the head are aligned. Insert the four 5 1/2" head bolts, the shorter of the six head bolts, into the corner holes, *hand tighten only*.
3. Position the top plate so the bolt holes on the plate and the head are aligned and put the two 6" bolts, the longer of the six head bolts, into the center of the head. Torque these bolts to 11 - 12 ft/lbs.
4. Put the two 1/4" screws in the holes at the edge of the top plate, through the plate, and into the head. Tighten to 9 - 10 ft/lbs.
5. Torque the hand tightened 5 1/2" bolts to 11 - 12 ft/lbs. First, tighten two which are diagonally across from each other, on opposite corners of the head. Then, torque the remaining two bolts.

**If you have questions, please call our technical support staff, toll-free, at 800-543-6400.**

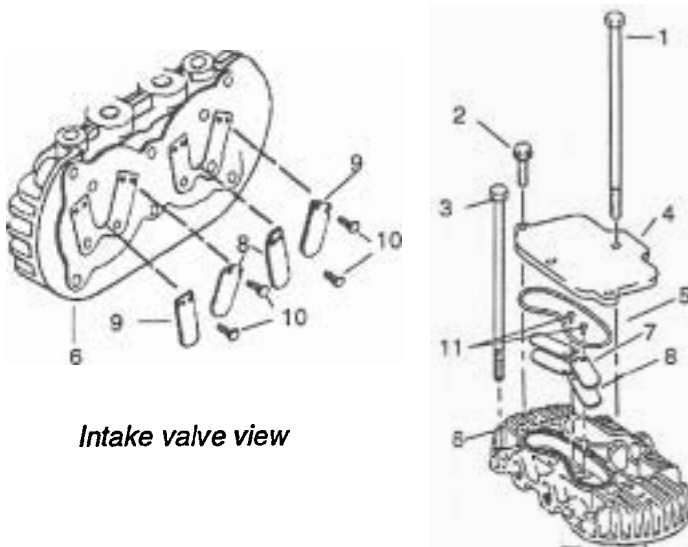

*Intake valve view*

*Exhaust valve view*

Key #	Part Number	Description
1		Cap screw, 5/16" - 18 x 6" (2)
2		Screw, 1/4" -20 x 3/4" (2)
3		Cap screw, 5/16" -18 x 5 1/2 (4)
4		Head top plate
5		O-ring
6		Cylinder head
7	VT021500AV	Valve restrictor, .048" thick (2)
8	VS001801AV	Flapper valve, .015" thick (4)
9	VS001800AV	Flapper valve, .008" thick (2)
10	ST073231AV	Screw, pan head, 1/4" long (8)
11	ST073261AV	Screw, pan head, 5/16" long (4)

**NOTE:** Key numbers one through six are *not* in this kit.