

**RIDGID  
R3002 RECIPROCATING SAW  
REPAIR SHEET**

**RIDGID  
R3002 SCIE ALTERNATIVE  
FEUILLE DE RÉPARATION**

**RIDGID  
R3002 SIERRA ALTERNATIVA  
LISTAS DE PIEZAS DE REPUESTO**

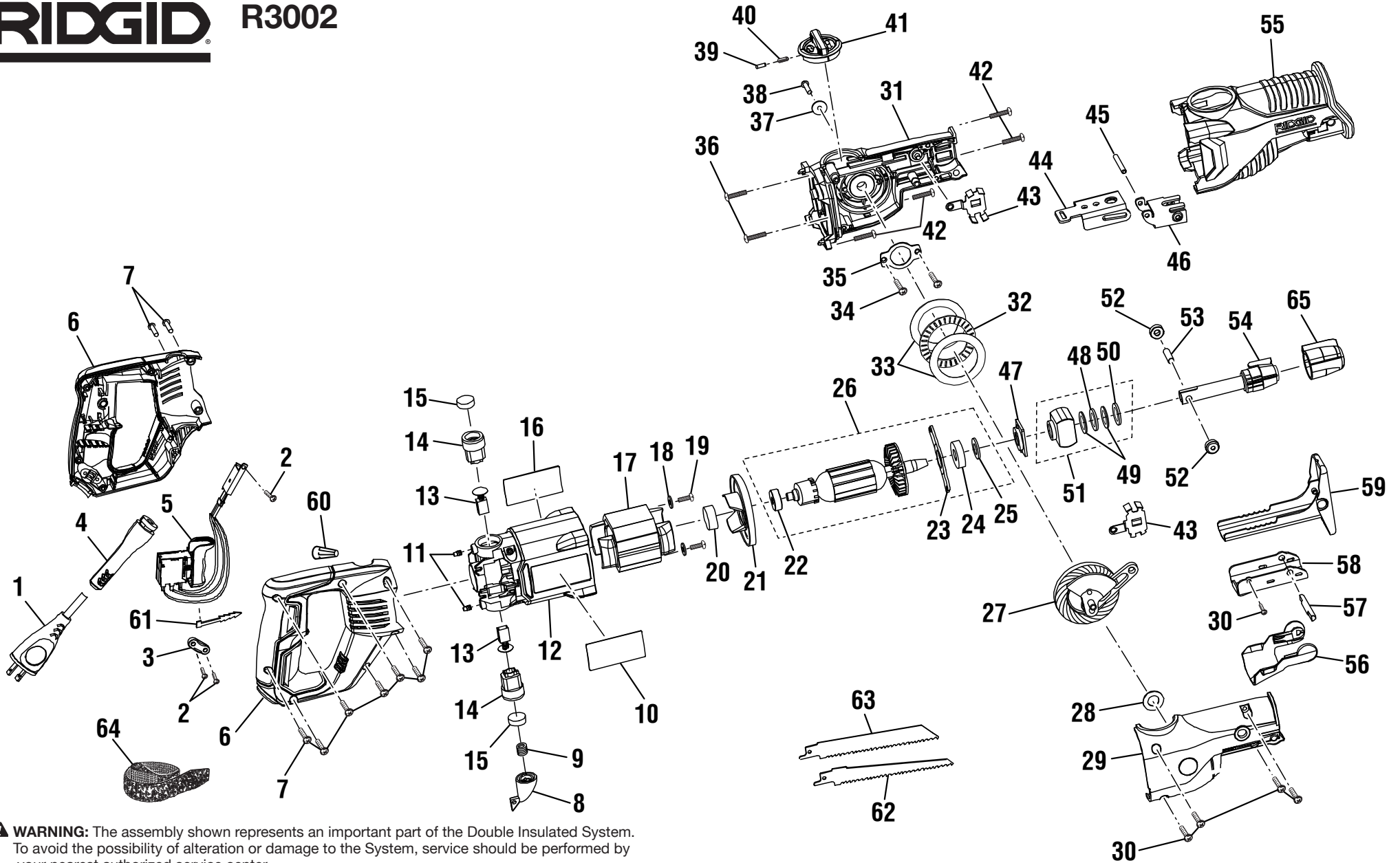

**▲ WARNING:** The assembly shown represents an important part of the Double Insulated System. To avoid the possibility of alteration or damage to the System, service should be performed by your nearest authorized service center.

**▲ AVERTISSEMENT :** L'ensemble illustré représente une partie importante du système à isolation double. Afin d'éviter la possibilité de modification ou de dommage au système, la réparation ne doit être effectuée que par votre centre de réparation commerciale autorisé.

**▲ ADVERTENCIA:** El conjunto que se ilustra representa una parte importante del Sistema de Aislamiento Doble. Para evitar la posibilidad de alteración o daño del sistema, la reparación debe ser efectuada en su centro de servicio autorizado.

# RIDGID® R3002

KEY	P/N	DESCRIPTION	QTY	KEY	P/N	DESCRIPTION	QTY	KEY	P/N	DESCRIPTION	QTY
1	730387005	Power Cord .....	1	25	516826001	Washer .....	1	48	901476001	Seal.....	1
2	660208052	* Screw (M4 x 16 mm) .....	3	26	200443012	Motor Armature Assembly (Incl. Key Nos. 22-25).....	1	49	632156001	Washer .....	2
3	5950101	Cord Clamp .....	1	27	302481001	Gear Linkage Assembly .....	1	50	672202001	Bushing Cap.....	1
4	560963001	Bend Relief .....	1	28	632447001	Washer .....	1	51	302303001	Spindle Bushing Assembly (Incl. Key Nos. 48-50).....	1
5	760406004	Switch.....	1	29	309994001	Right Gear Case Assembly .....	1	52	691260001	Spindle Bushing .....	2
6	200102007	Housing Assembly.....	1	30	661004001	* Screw (8-32 x 3/4 in., Torx).....	5	53	672179001	Pin .....	1
7	660024007	* Screw (M4 x 16 mm) .....	9	31	309995001	Left Gear Case Assembly.....	1	54	300132034	Blade Clamp Assembly .....	1
8	516827001	Brush Cap Cover .....	1	32	681238001	Thrust Roll Bearing.....	1	55	330706001	Rubber Boot.....	1
9	692035001	Compression Spring.....	1	33	632413001	Washer .....	2	56	302354001	Shoe Release Lever Assembly.....	1
10	940045224	Data Label .....	1	34	660549001	* Screw (M3 x 9 mm) .....	2	57	672196001	Shoe Pin .....	1
11	660067001	* Set Screw (8-16 x 1/4 in.).....	2	35	632331001	Bearing Retaining Plate.....	1	58	672197001	Shoe Retainer .....	1
12	516678001	Motor Housing.....	1	36	660165011	* Screw (M4 x 12 mm, Torx).....	2	59	302371001	Shoe Assembly.....	1
13	290255001	Brush Assembly .....	2	37	632442001	Washer .....	1	60	870126001	Wire Nut.....	1
14	513368001	Brush Holder .....	2	38	661214001	* Screw (M4 x 12 mm) .....	1	61	790002001	Cable Tie .....	1
15	517045001	Brush Cap .....	2	39	672747001	Orbital Detent Pin .....	1	62	671947001	Wood Cutting Blade .....	1
16	940114204	Logo Label.....	1	40	692009001	Compression Spring.....	1	63	671946001	Metal Cutting Blade.....	1
17	741094001	Field.....	1	41	302304001	Orbital Button Assembly .....	1	64	902018001	Cord Wrap .....	1
18	632508001	Washer .....	2	42	660436006	* Screw (M4 x 25.4 mm, Torx).....	4	65	561950001	Rubber Sleeve.....	1
19	660422005	* Screw (M4 x 50 mm) .....	2	43	632303001	Spindle Bushing Connector .....	2	<b>Not Shown:</b>			
20	561267001	Bearing Seat.....	1	44	672535001	Orbit Slot .....	1	66	902110001	Tool Bag .....	1
21	516679001	Baffle .....	1	45	672180001	Orbit Control Pin.....	1	67	987000307	Operator's Manual.....	1
22	680966001	Ball Bearing (608RS CW).....	1	46	672194001	Orbit Control Link .....	1	6-17-08 (REV:00)			
23	672198001	Bearing Retainer Plate.....	1	47	561963001	Bushing Seal .....	1				
24	690191001	Ball Bearing (6001RS CW).....	1								

\* Standard Hardware Item – May Be Purchased Locally



# RIDGID® R3002

NÚM. REF. N/P	DESCRIPCIÓN	CANT.	NÚM. REF. N/P	DESCRIPCIÓN	CANT.	NÚM. REF. N/P	DESCRIPCIÓN	CANT.
1	730387005	Cordón de corriente .....1	25	516826001	Arandela ..... 1	47	561963001	Sello del buje ..... 1
2	660208052 *	Tornillo (M4 x 16 mm) .....3	26	200443012	Conj. del inducido del motor (incl. pzas. núms. ref. 22 a 25)..... 1	48	901476001	Sello..... 1
3	5950101	Abrazadera del cordón.....1	27	302481001	Conjunto del acoplamiento del engranaje..... 1	49	632156001	Arandela .....2
4	560963001	Protector del cordón .....1	28	632447001	Arandela ..... 1	50	672202001	Tapa del buje ..... 1
5	760406004	Interruptor.....1	29	309994001	Conjunto derecha de la caja de engranajes..... 1	51	302303001	Conjunto del buje del husillo (incl. pzas. núms. ref. 48 a 50)..... 1
6	200102007	Conjunto de la armazón .....1	30	661004001 *	Tornillo (8-32 x 3/4 pulg., Torx).....5	52	691260001	Buje del husillo .....2
7	660024007 *	Tornillo (M4 x 16 mm) .....9	31	309995001	Conjunto izquierda de la caja de engranajes ..... 1	53	672179001	Pasador ..... 1
8	516827001	Retén de la tapa de la escobilla .....1	32	681238001	Rodillo de cojinete de empuje..... 1	54	300132034	Cojunto del mordaza para hoja ..... 1
9	692035001	Resorte .....1	33	632413001	Arandela .....2	55	330706001	Funda de goma ..... 1
10	940045224	Etiqueta de datos .....1	34	660549001 *	Tornillo (M3 x 9 mm) .....2	56	302354001	Conj. de afloje de la zapata..... 1
11	660067001 *	Tornillo de fijación (8-16 x 1/4 pulg.) .....2	35	632331001	Placa de retén del cojinete ..... 1	57	672196001	Pasador del zapata ..... 1
12	516678001	Alojamiento del motor .....1	36	660165011 *	Tornillo (M4 x 12 mm, Torx) .....2	58	672197001	Retención de la zapata..... 1
13	290255001	Conj. de tubo de la escobilla.....2	37	632442001	Arandela ..... 1	59	302371001	Conj. Zapata..... 1
14	513368001	Portaescobilla.....2	38	661214001 *	Tornillo (M4 x 12 mm) ..... 1	60	870126001	Tuerca de alambre..... 1
15	517045001	Tapa de escobilla.....2	39	672747001	Pasador orbital de trinquete..... 1	61	790002001	Amarra del cable ..... 1
16	940114204	Etiqueta logotipo ..... 1	40	692009001	Resorte ..... 1	62	671947001	Hoja para corte de madera ..... 1
17	741094001	Campo.....1	41	302304001	Conjunto de botón de órbita ..... 1	63	671946001	Hoja para corte de metal..... 1
18	632508001	Arandela .....2	42	660436006 *	Tornillo (M4 x 25,4 mm, Torx) ..... 4	64	902018001	Soporte para enrollar el cordón..... 1
19	660422005 *	Tornillo (M4 x 50 mm) .....2	43	632303001	Conector de buje del husillo.....2	65	561950001	Casquillo de goma ..... 1
20	561267001	Asiento de cojinete.....1	44	672535001	Ranura de órbita..... 1	<b>No se ilustra:</b>		
21	516679001	Deflector .....1	45	672180001	Pasador de control de órbita..... 1	66	902110001	Bolsa de herramientas ..... 1
22	680966001	Cojinete de bolas (608RS CW).....1	46	672194001	Acoplamiento de control de órbita... 1	67	987000307	Manual del operador ..... 1
23	672198001	Placa de retén del cojinete.....1						
24	690191001	Cojinete de bolas (6001RS CW).....1						

\* Artículo estándar de ferretería – Puede adquirirse en la localidad

**RIDGID**

R3002

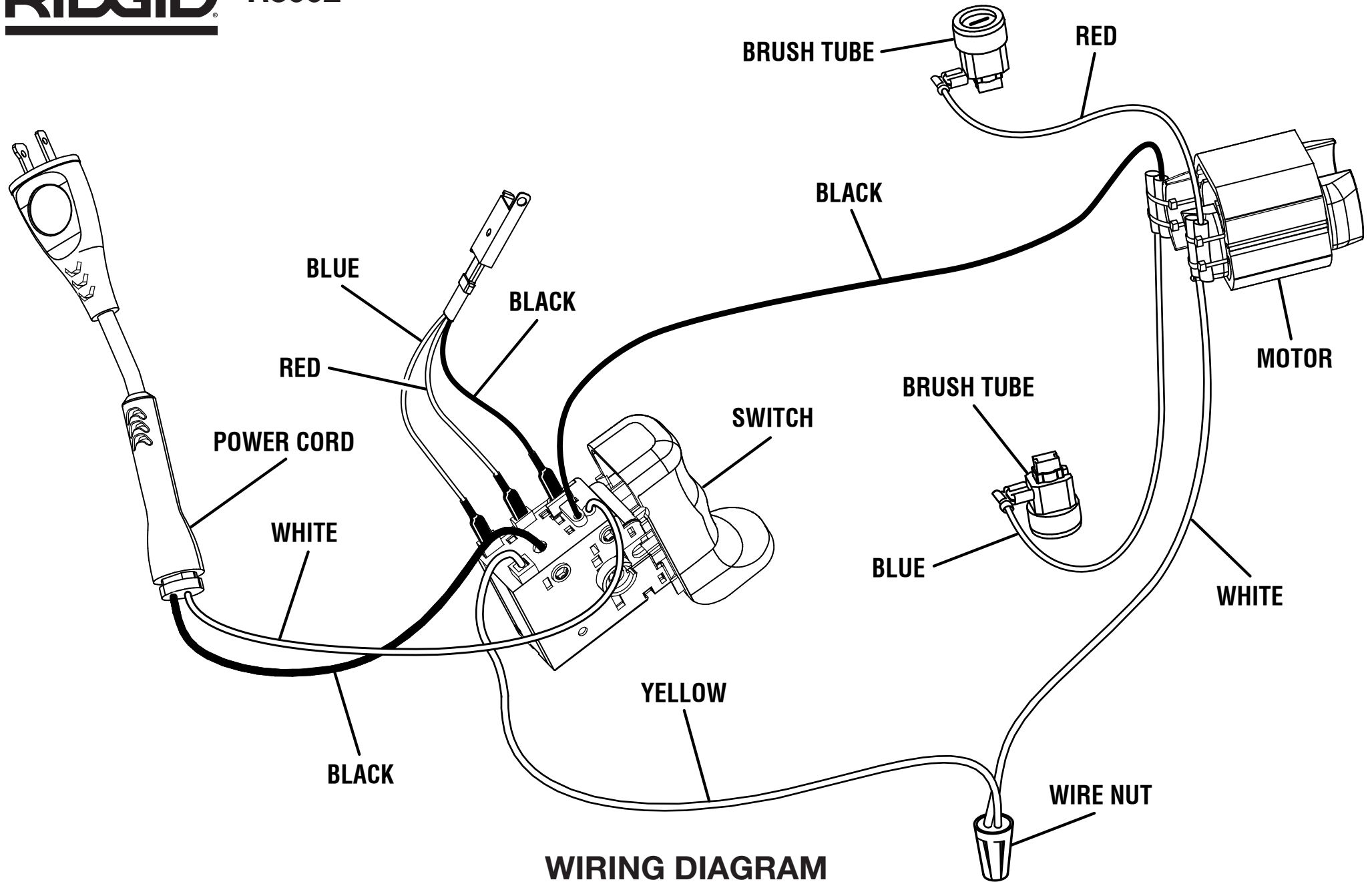

**WIRING DIAGRAM**